



User Manual



TTX 450/650/674/675/950/
1050 – Puma/Puma plus/Lion/
Lion plus/Tiger/TigerXXL –
S 45/65/95/105



TDI/XXtreme/S TDI

CONTENTS

General	4
Copyright.....	4
IMPORTANT OPERATING INSTRUCTIONS.....	4
Initiation	5
Unpacking of Printer.....	5
Set - Up and Connection of Printer.....	6
Connections TTX:.....	6
Connections -TDI:.....	6
Connection of External Units.....	7
Card Plug in Modules.....	7
SLOTS TTX.....	7
SLOTS TDI.....	8
Card hardware.....	8
PCMCIA card pin assignment.....	9
Memory types.....	9
PROM card (Programmable Read Only Memory).....	9
EPROM card (Erasable Programmable Read Only Memory).....	9
EEPROM or E ² PROM (Electric Erasable Programmable Read Only Memory).....	9
FLASH RAM / PROM card.....	10
RAM card (Random Access Memory).....	10
Card use.....	10
Card type.....	10
Set up mode	11
Winding Diagrams.....	11
TTX x50 / Wildcats.....	11
TDI / XXtreme.....	11
Insertion of Document Material.....	13
Material exchange.....	15
Insertion of fan folded material.....	15
Insertion of Thermal Transfer Ribbon.....	15
Adjustment of ribbon unwind rewind tension.....	17
Positioning of gap sensor.....	18
Adjust position of printhead.....	19
Adjust pressure of printhead.....	19
Adjustment to thickness of material.....	20
Installation of option.....	21
Short Tag Option	22
Fonts.....	22
Modes of operation - operation	23
New Start of Printer.....	23
Restart of Printer.....	23
Call of Program Version.....	23
Modes of operation - OFFLINE.....	23
Modes of operation - OFFLINE.....	24
Modes of operation - ONLINE.....	25

Maintenance and cleaning	26
Cleaning the printhead	26
Exchanging the printhead / TTX x50.....	27
Exchanging the printhead / TTX 67x.....	28
Cleaning of Print Roller	29
Clean feed roller for single tags -	30
TDI / XXTREME / S TDI only-	30
Clean Short Tag Option - TDI / XXTREME / S TDI only-	30
Cleaning of Punch-Recognition Sensor	30
Cleaning of ribbon guiding parts	31
Cleaning of knives - TTX 650 / LION / S 65 only -	31
Other	32
MATERIAL AND RIBBON	32
Material.....	32
Ribbons	32
Printer layout	33
Layout TTX.....	33
Layout TDI.....	34
Technical Specification TDI.....	35
Label Stock Specifications	36
Ribbon specifications	37
Fonts, Bar Codes	37
Operating Features	37
Connection, Device Data	37
Certificates	38
CE conformity.....	38
Service Data	38
INDEX	39

General

Copyright

This User Manual and its contents are subject to copyright. The publisher's prior written consent must be obtained for reproduction of the manual as a whole or part thereof.

Names are generally given without any reference to existing patents, registered patterns or designs, or trademarks. The omission of a corresponding note does not imply that the names can be used freely. All trademarks are acknowledged.

The manufacturer reserves the right to technical and other alterations without prior notice. The publisher cannot warrant the accuracy of the content of this manual.

Note: Please follow the notes shown in this text - it will help to cover all situations and keep your engine working.

IMPORTANT OPERATING INSTRUCTIONS



The following warning hints and precautions contained in these Operating Instructions must be strictly observed. This will considerably contribute to the safe and expert operation of your printer.

Warnings: Exclusively original parts and accessories available from the manufacturer are to be used to maintain the service life of your printer. The use of parts not in compliance with the exacting demands made by the manufacturer may result in unnecessary sources of danger.

The housing of the unit must exclusively be opened by authorised technical personal.

Insertion/Exchange of foil and material should be carried out only by especially instructed personnel (Set Up Mode!)

On operation with open cover, fingers, hair, clothes jewellery, et. may be caught by and get into the unit in the foil-feed section. Do not expose or operate the unit to moisture nor wet conditions.

Hazard of injury in the initialisation process and during cutting because of moving knife

Remove printhead not until 3 minutes after disconnection of unit.

Re connect unit not until 10 seconds after disconnection's.

Remove, insert or exchange Plug in Card not until 60 seconds after disconnection of unit.

Initiation

Unpacking of Printer

- Remove top foamed packing.
- For removing the printer off the box, take it at the base plate only and lift. A second person should assist by removing the cardboard box downwards.

Note: Front cover, motor of optional knife must not be used as carrying handles.

- Set unit to a plain and stabile desk.

• -TDI / EXXTREME / S TDI only-

- Mount paper tray in and out, bow and length position stick according to picture below
- Carry unit only by taking it at the base plate

Note: Front cover, motor of optional knife must not be used as carrying handles.

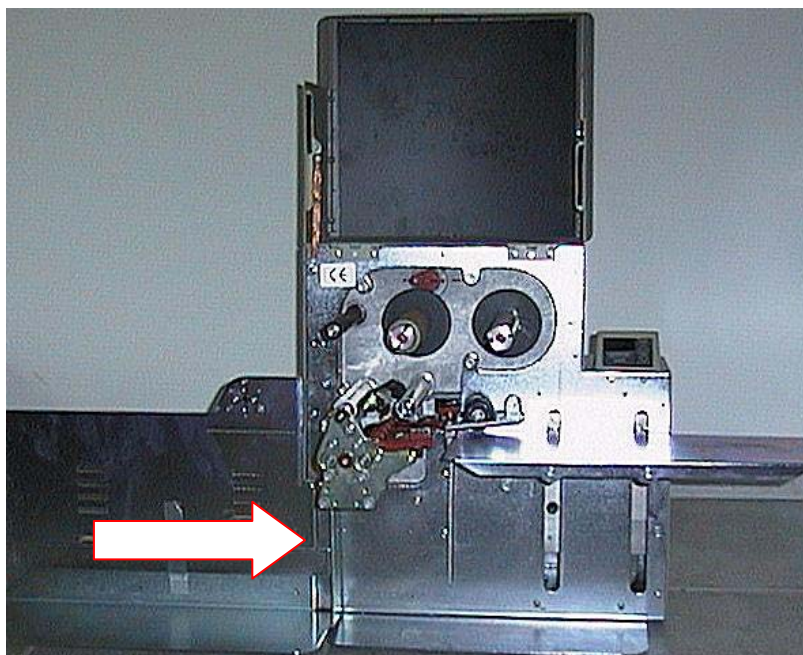

Set - Up and Connection of Printer



- Check mains voltage setting and fuses.
- The fuses can be replaced by turning the inserts .

Attention: Unplug mains power plug before checking/changing mains voltage or fuses!

Connections TTX:

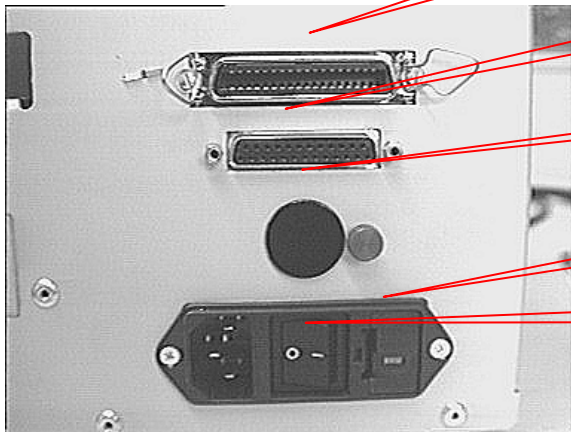

Centronics (parallel)

serial Inteface (RS 232 / RS

optionale connector

power select

power ON/OFF switch

Connections -TDI:

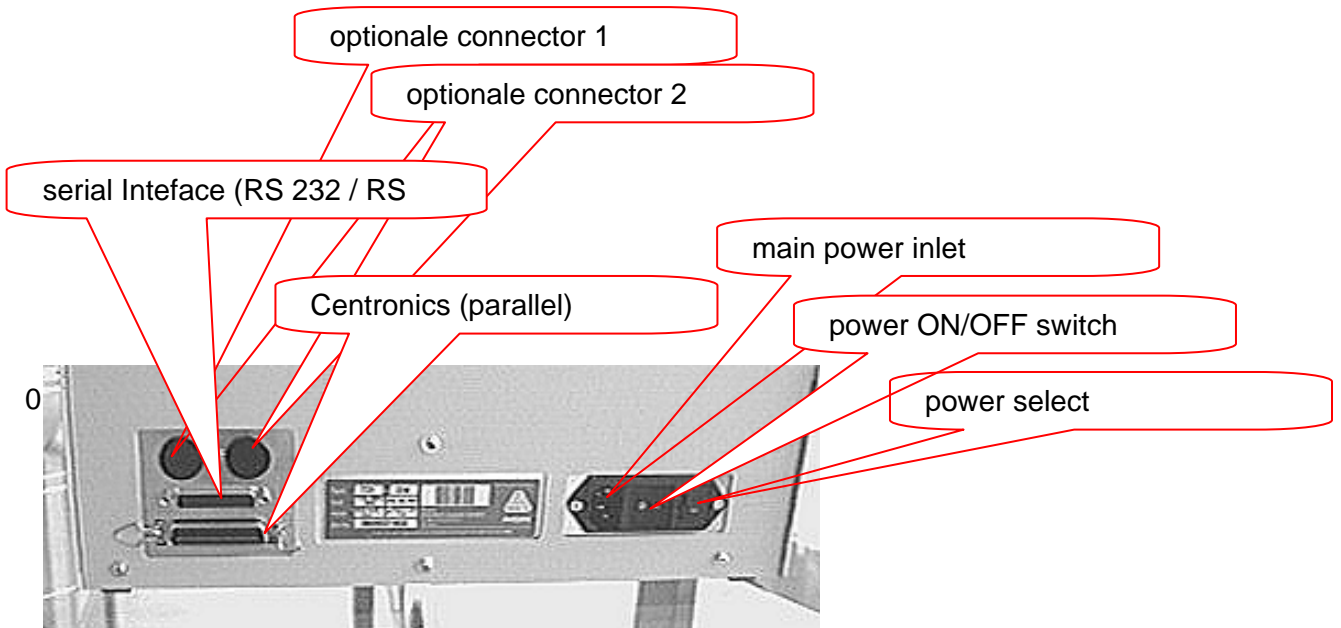

optionale connector 1

optionale connector 2

serial Inteface (RS 232 / RS

Centronics (parallel)

main power inlet

power ON/OFF switch

power select

Connection of External Units

A serial interface V.24/DB25 (RS232) and a parallel interface (Centronics) are integrated as standard for connection of the printer to the computer.

Optional there is a RS 485 interface available - the RS 232 can be (factory installed) removed and changed to a RS 485 interface. Be aware that the RS 232 interface then is removed !

The rear side of the unit is, in addition, equipped with one or two sockets for the connection of an external unit.

Attention: Turn off unit prior to plugging/unplugging interface cable/stacker connector
Exclusively units tested in accordance with IEC 950 and VDE 0805-which are in compliance with these standards according to SELV- must be connected to interface and stacker socket.

Card Plug in Modules

These plug in modules are provided for the optional font and logo cards. Use PCMCIA cards up to a size of 2 MB only. There is a maximum of 1 logo card alone or together with a font card – as well one or two font cards are possible. Logo Cards and data bank cards are formatted by the printer itself.

Font cards are to be programmed by supplier only.

Attention: Exclusively plug in cards approved by the manufacturer must be used Insert, remove, or exchange card not until 60 seconds after disconnection of unit.

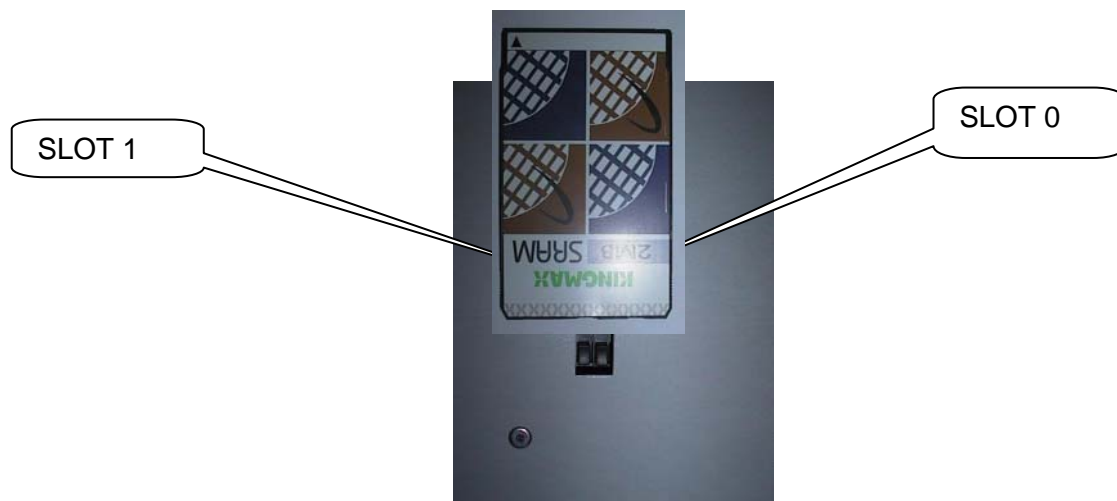

SLOTS TTX

SLOTS TDI

Card hardware

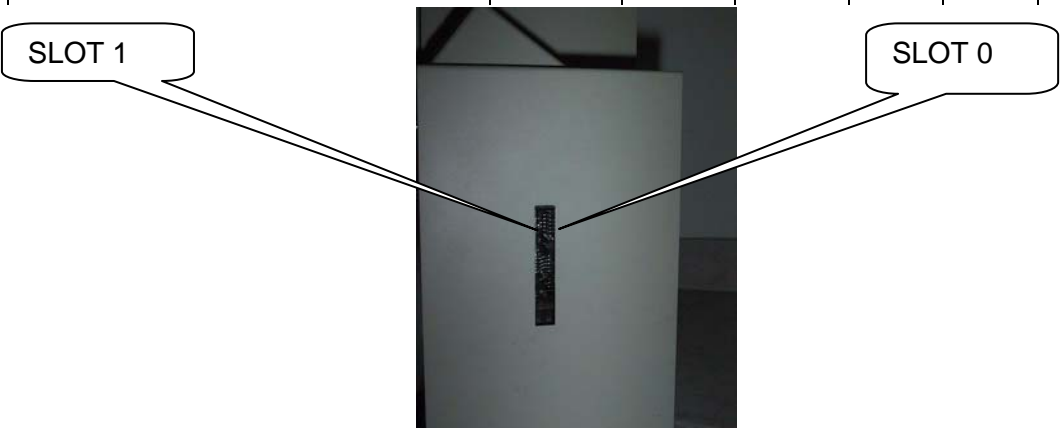
printer type	card type	quantity card	memory of card	PROM card	S-RAM card	Flash card
						
TTX 450/650/950/1050/Puma/Lion/Tiger/Tiger XXL	PCMCIA	2	2 MB	-	yes	yes
TDI	PCMCIA	2	2 MB	-	yes	yes

PCMCIA card pin assignment

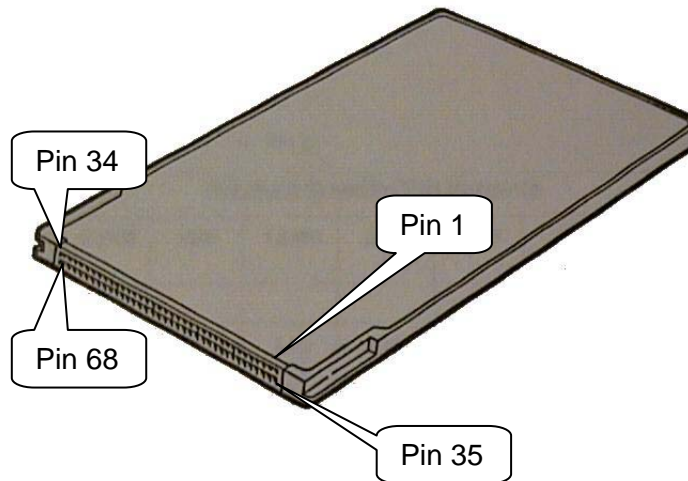

Memory types

PROM card (Programmable Read Only Memory)

Programmable only with a special program unit (EPROM burner) – it is a on time card, normally used to store fonts and logos witch are used again and again in the same shape size or look like. The card will be programmed in the factory due to the customer wishes. Memory size and capacity depends to the printer.

EPROM card (Erasable Programmable Read Only Memory)

Programmable only with a special program unit (EPROM burner) – it is a on time card, normally used to store fonts and logos witch are used again and again in the same shape size or look like. The card will be programmed in the factory due to the customer wishes. The difference between EPROM and PROM card is that the EPROM card can be cleared by using ultra violet light.

Is not used in our printer.

EEPROM or E²PROM (Electric Erasable Programmable Read Only Memory)

The function is similar to an EPROM card – to clear the memory there is no light used, it works with electric power. The clear procedure is very slow. The data are hold in the memory after power down – without battery !

Is not used in our printer.

FLASH RAM / PROM card

A name used and defined by the company INTEL which has used this technology first. The memory is built similar to the EEPROM but can be cleared in single sectors. A low voltage (5V) is enough to clear the memory and this voltage is available in the most places (PC/printer). The clear procedure is very fast, the data's are stored in the memory after power down – without battery.

This card is re programmable and can be programmed in a PC with the data's. Stored on this card type can be fonts and logos – same as on the EPROM card. In difference it is possible to store as well formats.

Memory size is different depending on card type and printer.

RAM card (Random Access Memory)

Very fast, volatile memory. Each single memory cell is programmable and readable. Using RAM card means that a battery is used to make the memory non volatile- the data's are still in the memory after power is switched off, reasoned by the power of the battery.

The card type is re programmable and depending on the printer type the card can be programmed in the printer (via download) or at the PC. It is possible to store – similar to the EPROM card, as well logos fonts but different to the EPROM card as well formats.

Memory size is different depending on card type and printer.

Card use

Depending on the printer type the cards can be used different. Attached you will find a table showing card type, menu point to clear the card – where the card has to be formatted – and as well the quantity of files.

card type	menu point	formatting	formatting	quantity of files
Easy Card Format Card	---		DOS	as much as you want (max. memory)
Logo Card	LCLR	intern		---
Font Card	DOWN	intern	DOS	one, „V55_CARD.BIN“
Speedo Card	DOWN	intern	DOS	one, „PROMFILE.BIN“
DOS Card	---		DOS	as much as you want
Database Card	DOWN	intern		one & Index
Barcode Card	---	intern		---
Image Card	ICLR	intern		---

Card type

Note: For more information please refer to the card manual.

Set up mode

Winding Diagrams

TTX x50 / Wildcats

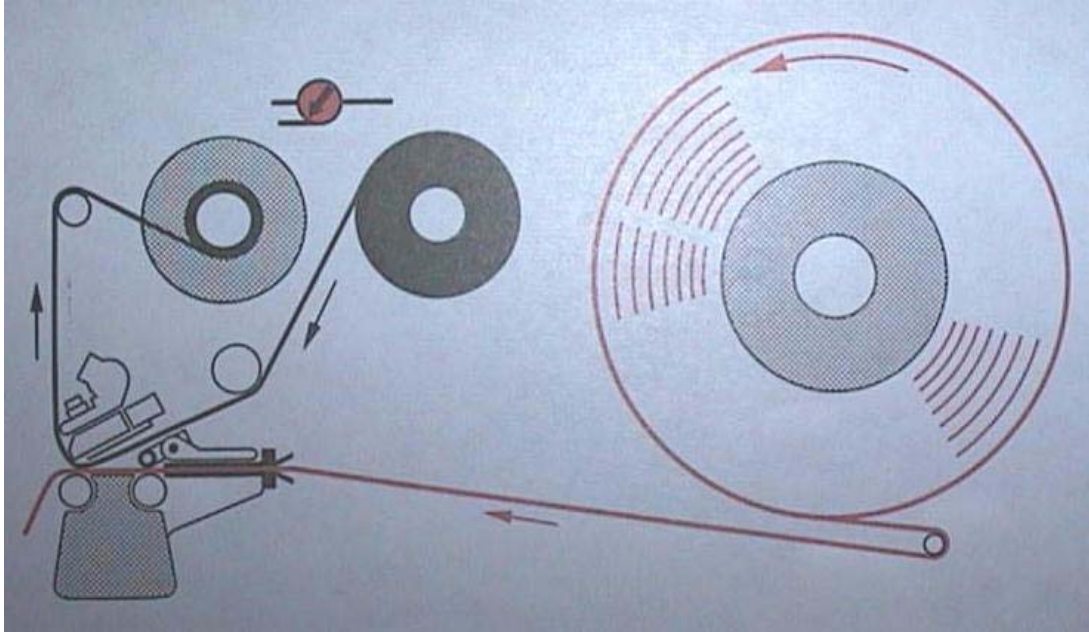

TDI / XXtreme

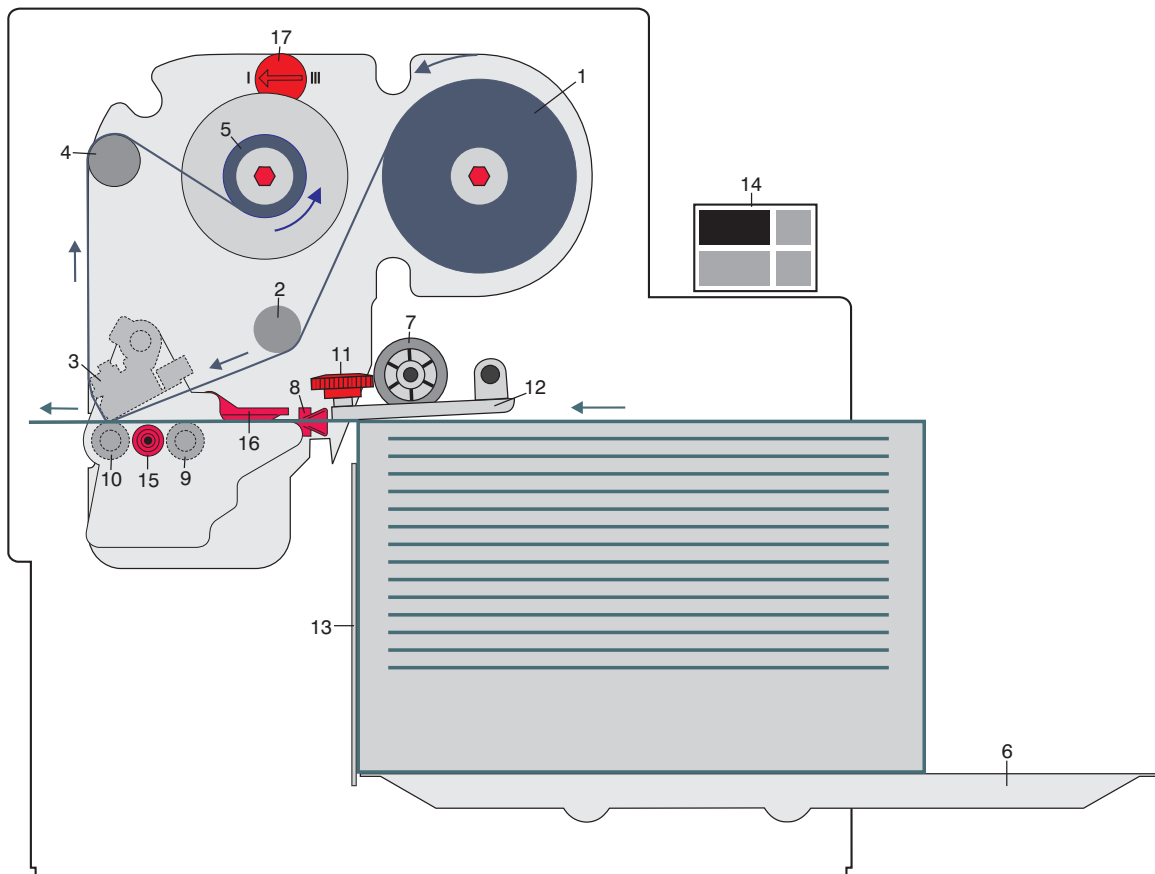

Z0133.cdr

Please follow during media / ribbon change the upper diagrams ! This is showing the used directions of ribbon and media (insert ribbon – insert media)

Attention : Sometimes it is helpful to release the head and rotate the head to insert ribbon into the printer (esp. For TTX 450 / Puma / S 45) ! As well rotating the head means that the wires connected to the head can be to short – then please disconnect the wires – only if the printer is switched OFF ! Do not forget to connect again – and check if the connectors are properly mounted !

This is shown in the following chapters as well.

Insertion of Document Material

Attention: Insertion/exchange of foil and material should be carried out only by especially instructed personal.

- Open front over
- -TTX 650 / LION / S65 only-

Hang document material in reel holder in a way to ensure anticlockwise unwinding. Put outer guide disk onto mandrel.

Guide material around the dancer.

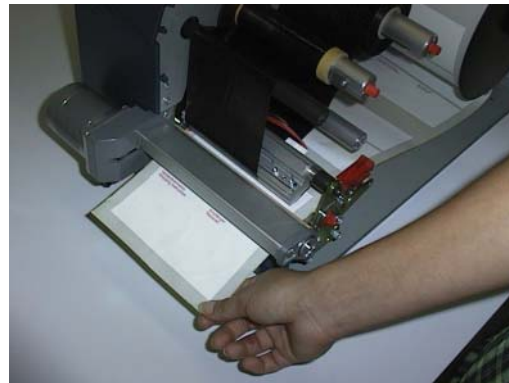

• - only for TTX 1050

there is a special support which has to be opened before media can be loaded or removed.

After removal or change of media – please close the support again.

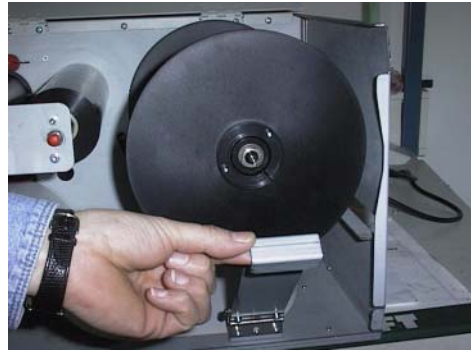
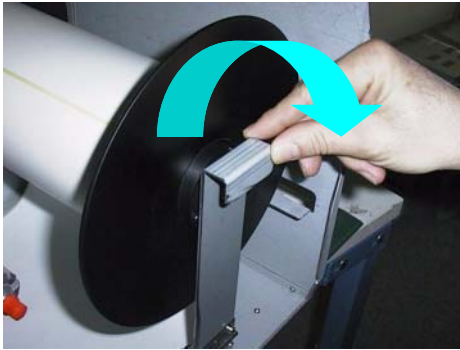

-TDI/ EXXTREME/S TDI only-

Move paper tray down by means of simultaneously pressing ON/OFFLINE and CUT key. Insert material to the left/rear corner of tray. Move paper tray up by means of simultaneously pressing ON/OFFLINE and FEED key.

- Adjust lateral material guides (red) that the material may move easily.

-TTX 650/ LION / S 65 only-

Press the red lift lever at the right, outer end of the print module in order to lift the pressure rolls of the feed roller and insert material below the printhead.

- Adjust both pressure roll units symmetric to material with so that material moves smoothly.
- On printer versions with installed knife a straight cut edge is required for perfect material insertion.



Attention: Do not touch feed unit with your free hand. The optional knife may cause injuries with wrong key manipulations! On operation with open cover, fingers, hair, clothes, jewellery, etc. may be caught by and get into the unit in the ribbon feed section.

Material exchange

- Switch printer to OFFLINE mode and lift printhead by brief pressing of the (FF)-key.
- Remove material by pressing the red lift lever and drawing the material backward.

- **-TTX 650 / LION / S 65 only-**

By pressing the ON/OFFLINE and CUT key simultaneously the material will be transported backward.

- **-TDI / EXXTREME / S TDI only-**

Move paper tray down by means of simultaneously the material will be transported backwards automatically.

- Remove material off the mandrel or paper tray.
- For continuing steps see description above.

Insertion of fan folded material

- **-TTX 650 / LION / S 65 only-**

- Remove blade at rear side of unit.
- Set outer material guide disk according to width of material.
- Insert material with imprint side up.
- For continuing steps see description: Insertion of material.

Insertion of Thermal Transfer Ribbon

- Attach ribbon reel onto foil mandrel on the right-hand side for anticlockwise unwinding of ribbon. Attach empty ribbon core onto mandrel on left-hand side.
- Insert ribbon end diagonally from the front under print-head holder or between knife cover and printhead holder with open hinge drive mechanism. If foil is changed during a print job, lift print head by short depression of the FF key.

- Pull ribbon upward and simultaneously move it towards printer.
- Guide ribbon around feed roller and attach it to ribbon core in anticlockwise direction (ribbon may be folded so that adhesive part at start of ribbon can be used).

- **-TTX 650/ LION / S 65 only-**

By simultaneous depression of the (ON/OFFLINE)-and (FF)-keys, material and ribbon can be advanced until perfect unwinding of ribbon is warranted.

- **-TDI/XXTREME / S TDI only-**

By pressing 2x the CUT key at OFFLINE mode at the display appears FOIL.

Subsequently by depressing the ON/OFFLINE key, the ribbon may be fed. Leave operation by pressing FFED key 2 times back to OFFLINE mode.

Attention: Fingers, hair, clothing, jewellery, etc. may be caught by and get into the unit in the ribbon feed section!

• - only for TTX 1050

Similar to the media unwind – the ribbon mechanic is supported as well. Open the handle to remove / change ribbon and close the support again.



Adjustment of ribbon unwind rewind tension

The torque of ribbon unwind and rewind mandrels are adjustable by means of the red hexagon pin .

The ribbon should run free of wrinkles respectively should not be stretched (especially at drum section) over the whole run from roll to roll.

Increase of torque at unwind rewind mandrel

Ribbon must not be stretched

Decrease of torque at unwind rewind mandrel

Ribbon must not have wrinkle

The factory adjustment covers a wide range of ribbon width which is the main factor for the torque. Use of very narrow and very wide ribbon however may need a readjustment.

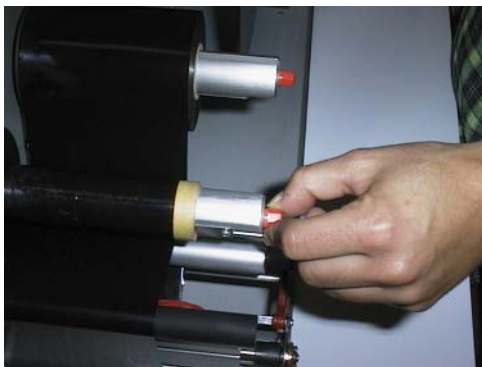

Adjust position of printhead

The zero line of the printhead can be varied from 2 - 13 mm of the left material edge
(this is only true for TTX 650, 950, 1050, TDI – not for the TTX 450)

- Loosen screw at center of printhead axle and set printhead to required position.

Attention: Printhead must not be plugged off !

- Fix screw
- Loosen black plastic disk at ribbon rewind and unwind mandrell by means of 2 mm allen key
- Adapt them both to position of printhead zero line and tighten again

Adjust pressure of printhead

Different material width may require different pressure of printhead to material in order to optimise the print quality.

- 3 grades are available.
- Rotate the adjustment disk by means of a coin or screwdriver to the required position.

Note: Select pressure only as high as necessary for the best print quality. Too high pressure may lead to damages at the printhead.

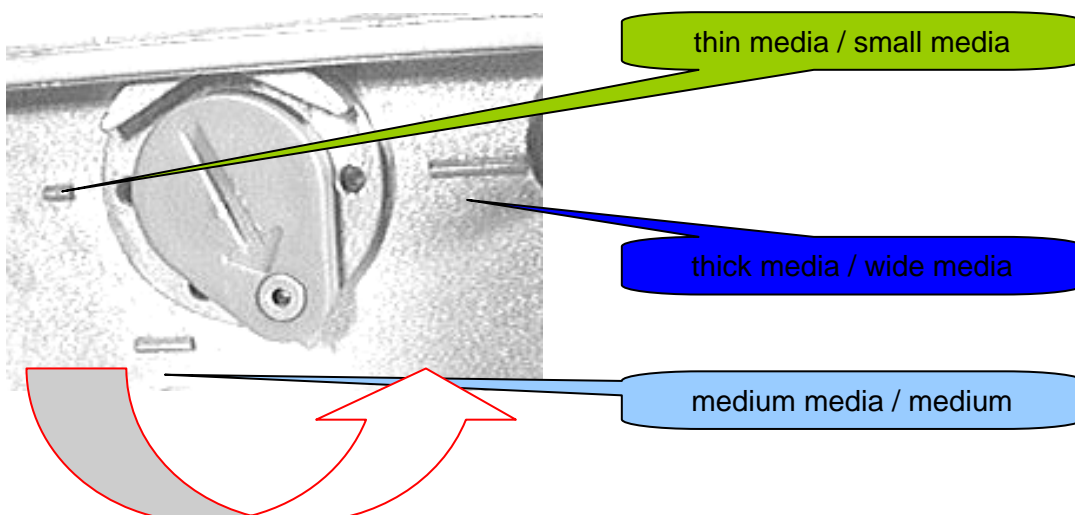

Adjustment to thickness of material

• -TDI/EXXTREME / S TDI only-

The function of separating / transport roll at the paper tray has to be adapted to different thickness of materials in order to ensure a correct label run.

The adjustment wheel is located between paper tray and lateral material guide, a bit offset in the base plate of the print module. It carries a red, a yellow and a green arrow.

Adjust following:

- When using thin material 2 and/or more tags are drawn in Rotate wheel clockwise
- When using thick material, none tag will be drawn in Rotate wheel anticlockwise

The coloured arrows may be positioned at the wheel in order to set marks for different types of tags.

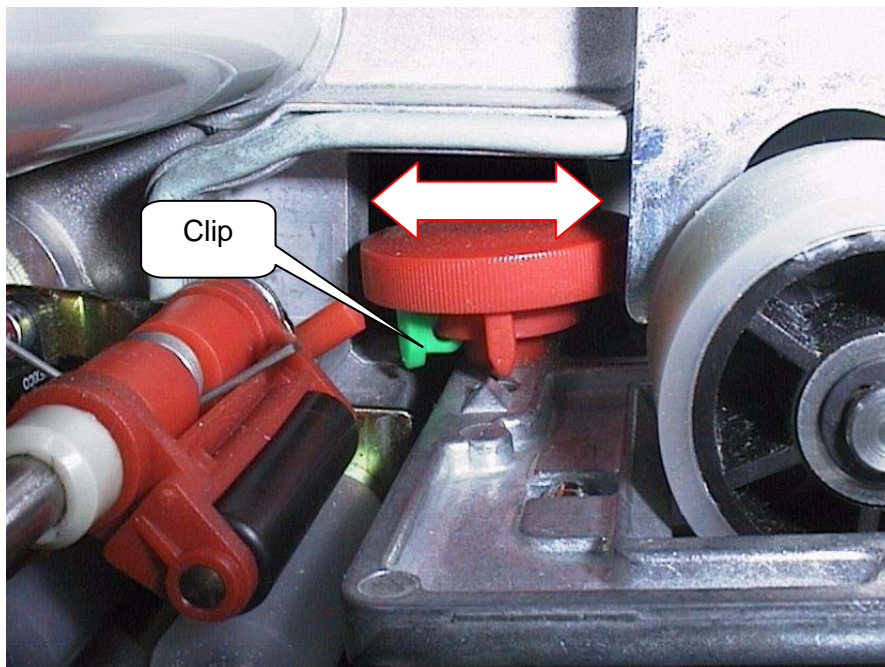

Installation of option

for TTX 650 / LION / S 65

Attention: Some of the options – like the dispenser module can only be mounted by service personal ! Sometimes it is necessary that a module can be imbedded only from a defines series number – see option manual.

Unplug main power supply!

- Plug light-barrier connector and motor connector in. Both sockets are located at front side of housing.
- Fasten unit by means of 2 hexagon socket screws at vertical base plate of printer.
- Reconnect power supply and switch unit on.

Attention: Hazard of injury in the initialisation process and during cutting because of moving knife!

- to activate the option go the parameter 'PEPH' and select the option with the necessary parameter
- follow the steps in the option manual



A special case is the color option – therefore you have to install a separat firmware and add an additional sensor. For more details refer to the color manual.

Short Tag Option

- for TDI / XXTREME / S TDI-

This option is used to handle short label (between 50 mm and 105 mm). The short tag option is a second feed system driven by the main feed roller. A belt is connecting the main feed roller with the short tag option. The label is transported from the separator to the short tag option and from there to the feed section of the printer.

Attention: The option can be mounted to a printer by a service technician from a defined serial number on ! From serial number SN 6800131605 on you can upgrade the unit definitely ! This can only be done by a service technician.

Activate the shot tag option under menu point SECF (select YES)

OFF

INFO PRTP IFAC SYSP

EMUL

NACH

SENS

PUNS

FMOD

OMOD

SMOD

MMOD

LPOS

SECF

YES?

Fonts

Most the fonts used in the printer firmware are proportional – only the **OCR fonts** are non proportional. This is given by the specs of this fonts.

Proportional font this means that all characters have a specific width

Non proportional font all characters have the same width

Modes of operation - operation

New Start of Printer

Connect printer to main power
Connect printer to computer

Switch on printer
Switch located at rear side of unit

Display: OFF

Acknowledge by ON/OFFLINE key
The printer is ready to receive data via the selected interface

Display: ON

Restart of Printer

Restart of printer without disconnection of unit by simultaneous operation of all three keys.

Note: All data stored in the printer will be deleted.

Call of Program Version

The program version is displayed during Reset – example 1H34



Modes of operation - OFFLINE



'FEED' and 'CUT' simultaneously = program or 'ESC'

'FEED' -'CUT' and ON/Offline simultaneously = Reset

OFFLINE MODE TTX 450, 650, 950 - S 45, 65, 95 - Puma, Lion, Tiger

Display	Key	Display	function
OFF	ON/OFFLINE	ON	ready to receive
OFF	ON/OFFLINE FEED	<--	slow media and ribbon movement
OFF	ON/OFFLINE CUT		cut and media backwards
OFF	FEED	FEED	feed of media
OFF	CUT	CUT	cut (if the optional cutter is available)
OFF	FEED CUT	INFO	enter the parameter menu

OFFLINE MODE TDI, XXTREME, S TDI

OFF	ON/OFFLINE	ON	printer is ready to receive data
OFF	ON/OFFLINE FEED	UP	move magazine up, if parameter MMOD = TAG
OFF	ON/OFFLINE CUT DOWN		move magazine down, if parameter MMOD = TAG
OFF	FEED	FEED	feed of media
OFF	CUT ON/OFFLINE	FOIL	slow ribbon feed, to stop press CUT
OFF	FEED CUT	INFO	enter parameter menu

status message

ST ..	ON/OFFLINE		press key to cancel the status
	FEED		turn off acoustic signal
	CUT		leave status message to OFFLINE mode

Modes of operation - ONLINE



'FEED' and 'CUT' simultaneously = program or 'ESC'

'FEED' - 'CUT' and ON/OFFLINE simultaneously
 = RESET

ONLINE MODE

Display	Key	Display	function
ON	FEED CUT	HV..	energy changing with FEED - (less) changing with CUT + (more)
WAIT	not possible	WAIT	image built up
XXXX process			display quantity of printable label including the one in
XXXX flashing	ON/OFFLINE	STOP XXXX	the label in process will be finished then the display starts
STOP XXXX	ON/OFFLINE	OFF	change to OFFLINE mode (quantity unchanged)
OFF	ON/OFFLINE	STOP XXXX	OFFLINE Mode – printout is stopped
STOP XXXX	FEED	XXXX	print job start again

Parameter menu coming from OFFLINE Modus

Display	key	display	function
OFF	FEED CUT	INFO	enter parameter menu
INFO	FEED CUT	OFF	leave parameter menu
INFO	FEED		selection
INFO	CUT		selection

Maintenance and cleaning

Clean printhead and feeding roller with cleaning liquor from paper, adhesive and ink deposits at regular intervals.

Cleaning the printhead

- Disconnect unit

Attention: Pull off mains plug!.

- Remove material and ribbon.

- Loosen hexagon socket screw at center of printhead axle by means of a 2mm allen key, until the printhead can be rotated clockwise.

Attention: The printhead is an electronic module and highly sensitive to static impacts. For that reason discharge your static potential before going in contact with the printhead by gripping the base plate of the printer. Do not remove plugs from the printhead. If printhead is readjusted at axle mark ist position accordingly.

- Clean print roller with dust-free cloth and cleansing liquor only.

Attention: Never use knives or objects with sharp edges for cleaning. Metal objects must never get in contact with the dot line.

- Put printhead to former position and fix screw again.

Note: The screw enters a non visible gap at the axle, which ensure the correct position of the printhead. Factory adjustment is flash with the inner black plastic bushing.

- Before switch on the unit, check that both connectors of printhead are still plugged on correctly. Reconnect if necessary.

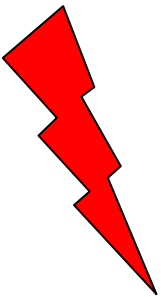

Exchanging the printhead / TTX x50

1. Disconnect unit

Attention: Pull out the mains plug!

2. Remove material and ribbon.
3. Remove plugs from printhead in horizontal direction.

Note: Remove printhead cable from printhead not until 3 minutes from disconnection of unit.

4. Loosen the 2 red marked screws at fixation of printhead.
5. Loosen screw at center of printhead axle - until the printhead fixation can be rotated clockwise.

Attention: The printhead is an electronic module and highly sensitive to static impacts. For that reason discharge your static potential before going in contact with printhead by gripping the base plate of the printer. If printhead is readjusted at axle mark its position accordingly.

6. Let the printhead down to print roller and rotate the fixation clockwise.
7. Draw printhead carefully out of the print module.

Attention: Metal objects must never get in contact with the dot line. Do not touch printhead at dot line or connectors.

8. For reassembling putt the printhead on the 180° rotated fixation, positioning is done by means of the 2 upright bolts.

Note: Before mounting notice the resistor value of the printhead-noted at printhead. Special care is to be taken that printhead is supported flush on mounting plate.

9. Keep printhead and fixation together with fingers, rotate anticlockwise to print roller.
10. Refix printhead by means of the 2 red marked screws at fixation bar.
11. Put printhead on axle to former position and fix screw again.

Note: The screw enters a non visible gap at the axle, which ensures the correct position of the printhead. Factory adjustment is flash with the inner black plastic bushing.

12. Plug on the 2 connectors to printhead.
13. When exchanging the printhead the value of the head resistor has to be keyed in after restart.

Attention: Entry of an incorrect value may damage the printhead!

14. Repositioning of printhead to print roller

Production tolerances at printhead may cause to move the printhead in or versus print direction. This is performed by twisting the little screws at the guiding tooth when fixing screws are loose (tools are supported with printer)

Note: The optimal position can be found by print only !

Exchanging the printhead / TTX 67x

The print head is adjusted to the print head mounting during manufacture. As a result the print head can only be replaced in conjunction with the print head mounting.

1. Switch off the device.
2. Pull out the mains plug.
3. Remove material and ribbon.
4. Pull out both plugs in a horizontal direction from the print head.

Note: Wait at least 3 minutes after switching off the device before removing the print head cable from the print head. Mark the position of an axially adjusted print head.

6. Unscrew the two thumb screws on the print head mounting until the entire print head mounting can be removed from the contact shaft (see Fig. 1:).

Fig. 1: Take care not to touch the connector contacts (1) or the thermal edge (2) when removing the printhead!

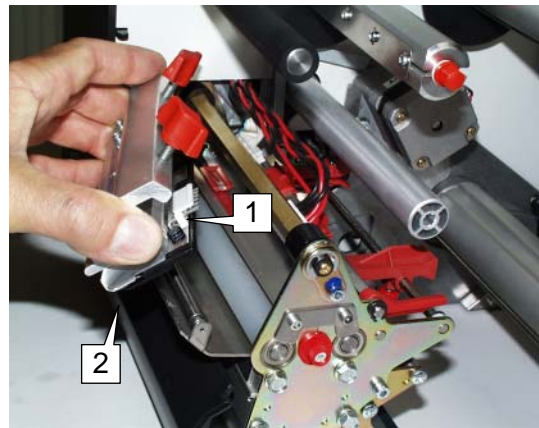

Attention:  The print head is a sensitive electronic component and can be damaged by electrostatic charges. Therefore, discharge any bodily static electricity before coming into contact with the print head by touching the base plate of the printer. The print head may not be touched on the print bar or on the plug-in contacts.

8. To install, move the new print head mounting to the old position and tighten the thumb screws.

Note: Before doing this make a note of the resistance value of the print head (read off from the print head). When placing the print head on the print head mounting, ensure that the print head is lying flat.

Note: Press the thumb screw on the tapered edge of the square axle and ensure the exact positioning of the print head mounting on the axle. Also pay attention to the position of the print head in relation to the edge of the label.
Basic factory settings: Flush against the inner black plastic plug.

9. Plug the print head cable back into the print head.
10. The resistance value of the print head must be entered after putting the printer into operation using the parameter "SYSTEM PARAMETERS/ Head resistance".



Attention: Entering a false value can damage the print head!

Note: Please also read the Service Manual, topic section "Service print module", paragraph "Exchanging the printhead".

Cleaning of Print Roller

- Disconnect unit

Attention: Pull off mains plug!

- Remove material and ribbon.

Loosen screw at center of printhead axle - until the printhead fixation can be rotated clockwise.

Attention: Do not remove plugs from the printhead. If printhead is readjusted at axle mark its position accordingly.

- After performance of this step, the feed roller as well as the print roller is accessible from above.
- Clean print roller with dust-free cloth and cleansing liquor only.
- Rotate roller stepwise for complete cleaning.

Attention: Never use knives or objects with sharp edges for cleaning.

The feed roller and the friction rollers are also to be cleaning from time to time. Performance of the printer and particularly the printhead is generally increased by avoiding any type of contamination in the printing area.

In addition, neat printing results are preferable to poor ones in any case.

- Put printhead to former position and fix screw again.

Note: The screw enters a non visible gap at the axle, which ensures the correct position of the printhead. Factory adjustment is flash with the inner black plastic bushing.

- Before switch on the unit, check that both connectors of printhead are still plugged on correctly. Reconnect if necessary.

Clean feed roller for single tags -

TDI / XXTREME / S TDI only-

- switch off device

Attention: Pull off mains plug!

- the feed roller should be cleaned with a dust free towel together with the Avery roller cleaner

From time to time the separation edge and the bearings should be cleaned
Cleaning will help to extend the runtime of your device !

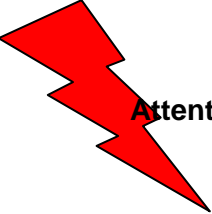

Attention: Cleaning of that roll on a regular basis is influencing the accuracy of the imprint of your device. Please clean at least two times a day !

Clean Short Tag Option - TDI / XXTREME / S TDI only-

- switch off device

Attention: Pull off mains plug!

- if the Short Tag Option is built in, you have to clean the additional feed roller as well – use a dust free towel ad the Avery roller cleaner.
- please clean as well the pressure roller

Cleaning of Punch-Recognition Sensor

According to the materials applied, the light barriers is to be cleaned from material residues and dust by means of compressed air.

- Disconnect unit

Attention: Pull off mains plug!

- Remove material and ribbon.
- Loosen screw at center of printhead axle - until the printhead fixation can be rotated clockwise.

Attention: Do not remove plugs from the printhead. If printhead is readjusted at axle mark its position accordingly.

- After performance of this step, the sensor are accessible from above.
- Clean sensor with air pressure only.

With heavy contamination additional cleaning using a dust-free cloth and cleansing liquor is recommended.

- Put printhead to former position and fix screw again.

Note: The screw enters a non visible gap at the axle, which ensure the correct Position of the printhead. Factory adjustment is flash with the inner black plastic bushing.

- Before switch on the unit, check that both connectors of printhead are still plugged on correct. Reconnect if necessary.

Cleaning of ribbon guiding parts

Adhesive residues are to be removed at regular intervals upon processing of self-adhesive material to ensure perfect print quality.

Clean parts with dust-free cloth and cleansing liquor only.

Contaminated parts affect the feed of the ribbon and will reduce the print quality.

Cleaning of knives - TTX 650 / LION / S 65 only -

Adhesive residues are to be removed at regular intervals upon processing of self-adhesive material to ensure perfect material cut and unwinding.

Attention: Pull of mains plug

Be aware of sharp edge of knife which could cause injury.

Remove adhesive residues from upper and lower knife; in case slightly swivel knives for better access to the entire edge.

Clean parts with dust-free cloth and cleansing liquor only.

Other

MATERIAL AND RIBBON

Material

The printer is equally suitable for thermal and thermal transfer printing. Three factors are to be taken into account when choosing the material:

- Abrasive behaviour of the surface structure
- Properties with respect to chemical reaction on print-colour transfer
- Temperature required for colour- transfer

If the material is extremely abrasive, the printhead is faster worn as usual. This criterion is particularly to be considered with thermal printing. It is not so critical with thermal transfer printing, as for this process a ribbon of a width exceeding the width of the material can be used. In this way the printhead is protected over the entire material width.

Similar conditions prevail with a high printhead temperature. Material and foil require a longer cooling down period, the printing quality is more critical and the printhead is faster worn as on a normal rate.

Printing on materials with a higher specific weight than 240gr/sqm, slight corrections of printhead pressure and position of printhead may be necessary.

Ribbons

Ribbons are recommended to be:

- the rear side has to be coated with an anti static and friction reducing media (back coating)
- suitable for print speeds up to 12 inches/second
- specified to „Near edge type printhead“
- wider as the material, i. e. the ribbon overlap the edges of the material by appr. 1-2 mm each side.

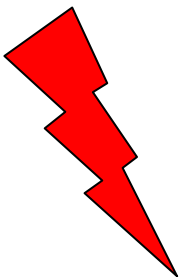

Ribbons without these features may reduce printer performance and printing quality, in some cases even the printhead may become defect.

Layout TDI

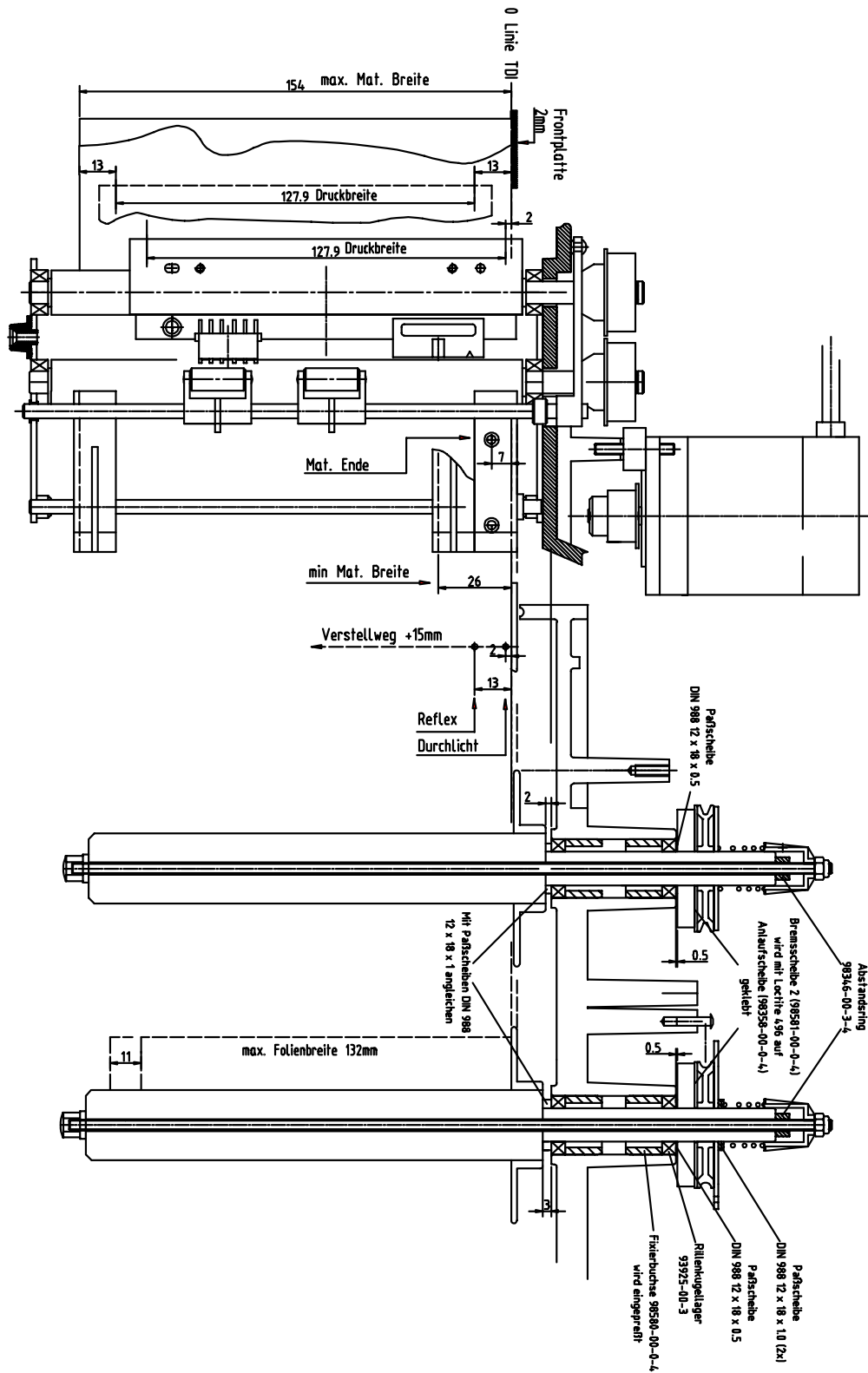

Technical Specification TDI

Print technology	Thermal-and Thermal Transfer Print
Print head	„Near Edge Type“ print head, high resolution, fast, with integrated temperature control.
Print speed	100 up to 250 mm/s in steps of 25,4 mm/s (1 “/s)
Resolution	12 Dots/mm (300 dpi)
Effective print width	128 mm
Imprint exactness	Up to 100 mm label length: +/- 1 mm in X and Y direction More than 100 mm label length: 1% of the label length
Label size	Width: 25,2 (short tag 50mm) up to 154 mm Length: 105 mm (short tag 50mm) up to ca. 350mm
Label length	105 mm up to max. printing length (standard device) 50 mm up to max. printing length (Short Tag option) The max. printing length depends on the following points: <ul style="list-style-type: none"> – <i>Firmware</i> intalled to the printer (standard or extended, furthermore of the version of the respective firmware) – Use of <i>bar code cards</i> – Use of <i>image cards</i> <p>Depending on the combination of firmware, bar code card and image card results a different maximum print length.</p>

Firmware	Plug-in card	Max. printing length
Standard (1H..)	none	301 mm (324 mm*)
	Bar code card	242 mm
Extended (1X..)	none	245 mm
	1 x 1 MB S-RAM	339 mm
	1 x 2 MB S-RAM	679 mm
	2 x 2 MB S-RAM	1359 mm
	Bar code card	197 mm

Tab. 1: The max. printing length can be extended by aid of S-RAM cards; assuming that the special "extended firmware" (code 1X..) is installed. This firmware takes more memory space than the standard firmware, that's why the max. printing length with extended firmware and without plugged-in S-RAM card is even lower than with standard firmware.

*) with spooler set to 8 KB (standard: 65 KB)

- Be aware, that the max. printing length may vary from one firmware version to the next. Adding features to the printer means often taking away some millimeters of printing length from the image buffer!
- For detailed information on the different firmware versions refer to the service manual, topic section "Firmware", "Firmware Versions".
- For details about applying plug-in cards refer to the cards manual.

Output mode 1:1 at 100% imprintable label area with or without cut.
 Not imprintable area: 2 mm from lower side and 1 mm from left
 (inner) side (fig.)!

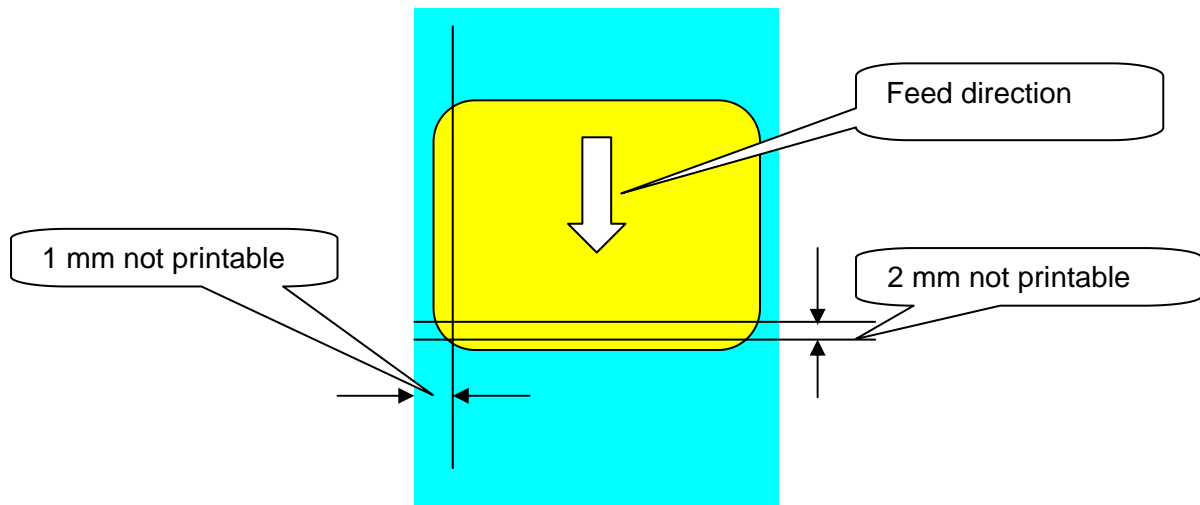

Gap sensor Self initializing infrared gap sensor with adjustment range 2-17mm,
 correction of gap offset possible; length of gap: 0,8 up to 14mm,
 width: min. 4mm; optional reflex mark sensor

Interpreter Easy Plug, Line Printer, Hex Dump

Label Stock Specifications

Label stock Fan folded, single sheet or strip

Width 25.4 up to 154 mm (standard device)
 50.0 up to 154 mm (Short Tag option)

▣▣▣▣▣ Special case for Short Tag Option: Suitable tag stock can be used
 without the outer material guiding. In those cases, the minimum width
 is 30.0 mm.

Type of stock Self-adhesive, tag or plastic label material

Thickness 0.1 to 0.5 mm

Weight 100 to 240 g/m²

▣▣▣▣▣ *Not suitable* is:

- Label stock with static charging surface
- Label stock with adhesive surface

Crucial for the function is also the separability of the label stock:

▣▣▣▣▣ The label stock must generally be easy to separate, what means:

- it must not be talcum-powdered.
- it must be free of punching burrs.

▣▣▣▣▣ Label stock with *sharp cutting edges* must be processed so that the
 cutting edge faces the print roller! (otherwise printhead service life will
 be decreased considerably)

○ Continued overleaf.

- Label stock which is thicker than 0.25 mm and/or heavier than 240 g/m² must be tested regarding printability. The testing must be done with a sufficiently large number of labels. Given a poor print result, the printhead position must possibly be changed.
- See “Service Manual TTX 67x”, topic section “Service print module”, chapter “Adjusting the print head position”.

Ribbon specifications

Ribbon roll	Roll max. outer Ø 90mm, inner Ø 1“ (25,4 mm)
Width	30 up to 132mm
Auto Economy Mode	Starting up from > 10 mm imprint free length (on the last 32 mm of a label only if SYSP/FMOD/SAVE is set to LEHU)

Fonts, Bar Codes

Fonts	17 Fonts inclusive OCR-A and OCR-B; 2 scaleable fonts
Character modification	Margination in X/Yup to factor 8, rotation: 90,180,270 degrees
Barcodes	EAN 8 and 13 with Add-On 2 and 5, UPC-A, UPC-E, Code 93, Code 39 (Ratio 1:2, 1:2,5 and 1:3), Code ITF, Codabar, Code 128, Code 2/5, Code 2/5 Interleaved (Ration 1:2 and 1:3), Code 2/5 5, Code 2/5 Matrix (Ratio 1:2, 1:2,5 and 1:3), Code MSI, Code EAN 128, Postcode (Lead-and Identcode), UPS-Code 128 All bar codes in 16 widths, unlimited in height.

Operating Features

Operation	3 key panel with 4 digit display.
Adjustments	Definition of parameters via menu or Easy Plug commands.
Test print outs	of parameter adjustments, downloaded logos, font, line, and barcode library.
Test functions	Print tests with cut, Test routines to memory and sensors
Error messages	Shows error messages on the display; continuation of print jobs without label loss

Connection, Device Data

Mains voltage	115/230/240 V +/- 10%, switchable
Mains frequency	50/60 Hz
Power consumption	336 VA
Current	approx. 3 A at 115 V and 1,5 A at 230/240 V
Fuses	8 A at 115V, 6,3 A at 230 V and 6,3 A at 240 V
Ambient conditions	Operation temperature: +5 up to +35 degree C Storage temperature: -20 up to + 70 degree C Humidity: 45 to 75%, non condensing
Dimensions WxHxD	840x420x380mm

Weight	Approx. 25kg - without stock
Interfaces	Standard: serial (RS 232) and parallel (Centronics) optional RS 485 - in exchange against RS 232
Memory	1MB dynamic RAM
Cards	2 Slots for PCMCIA cards, 2 MB each

Certificates

TÜV GS	Approved security (according to EN 60950:97)
--------	--

CE conformity

The devices are marked with the CE label. The manufacturer declares that the device conforms with the relevant European guidelines.

EMC	<p>The EMC tests were performed according to the following norms:</p> <p>EN 55022:98 EN 55024:98 EN 61000-3-2:95 EN 61000-3-3:95 EN 61000-6-2:99</p>
-----	--

Service Data

The data shown in STA3 can have a maximum value – shown in the table below. After that value is reached the counter is set to zero and counts up again.

Number of service operations	255
Number of heads / rolls / knives	255
Head / roll run length	131 km
Cuts on knife	4.300.000.000
Total material length	430.000 km
Total foil length	430.000 km
Total number of cuts	4.300.000.000
Head moves	4.300.000.000
Head strobes	4.300.000.000
Operation time	8.800 years

INDEX

<p>C</p> <p>Card..... 7</p> <p>Changing the print head 28</p> <p>Charges, electrostatic..... 28</p> <p>Cleaning of Print Roller..... 29</p> <p>Cleaning of ribbon guiding parts..... 31</p> <p>Cleaning Printhead 26</p> <p>Connections</p> <p style="padding-left: 20px;">TDI..... 6</p> <p style="padding-left: 20px;">TTX..... 6</p> <p>CONTENTS..... 2</p> <p>Copyright 4</p> <hr/> <p>E</p> <p>EMC..... 38</p> <p>Exchanging the Printhead 27</p> <p>External Units 7</p> <hr/> <p>F</p> <p>Fanfolded material 15</p> <p>Font cards..... 7</p> <hr/> <p>G</p> <p>Gap sensor 18, 36</p> <p>General..... 4</p> <hr/> <p>I</p> <p>INFO 24</p> <p>Initiation 5</p> <p>Insertion of Document Material..... 13</p> <p>Interpreter 36</p> <hr/> <p>K</p> <p>Knife option, installing..... 21</p> <hr/> <p>L</p> <p>Layout..... 33, 34</p> <hr/> <p>M</p> <p>Maintenance and cleaning..... 26</p> <p>Memory types 9</p> <p>MMOD 24</p>	<p>O</p> <p>OFFLINE 25</p> <p>ONLINE MODE 25</p> <p>Operating instructions</p> <p style="padding-left: 20px;">Printhead..... 4</p> <p style="padding-left: 20px;">operation 4, 23, 24, 25</p> <p style="padding-left: 20px;">Other..... 32</p> <hr/> <p>P</p> <p>parallel interface 7</p> <p>parameter 24</p> <p>PCMCIA card, pin assignment 9</p> <p>Plug-in cards</p> <p style="padding-left: 20px;">FLASH RAM / PPRAM card 10</p> <p style="padding-left: 20px;">PROM card 9</p> <p style="padding-left: 20px;">RAM card 10</p> <p style="padding-left: 20px;">use 10</p> <p>printhead..... 19, 26, 30, 32</p> <p>Printhead</p> <p style="padding-left: 20px;">adjust position of 19</p> <p style="padding-left: 20px;">adjust pressure..... 19</p> <p>Program Version..... 23</p> <p>PROMFILE.BIN 10</p> <p>Putting into operation..... 29</p> <hr/> <p>R</p> <p>Resistance value thermal bar 28</p> <p>Restart..... 23</p> <p>rewind 19</p> <p>Ribbon 15, 32</p> <p>Ribbon mandrels, setting torque..... 17</p> <p>Ribbon roll dimensions 37</p> <p>RS 232..... 7, 37</p> <p>RS 485..... 7, 37</p> <hr/> <p>S</p> <p>SECF 22</p> <p>Sensor 30</p> <p>Set up mode 11</p> <p>Short Tag Option 22</p> <p>status message 24</p>
---	---

T

thickness of material	20
Torque adjustment of ribbon mandrels	17

U

Unpacking printer	5
unwind	19