

# SLS – SCALABLE LAB SYSTEM™

BENCHTOP POWDER  
PROCESSING  
PLATFORM

Lab-scale interchangeable  
powder milling and screening



# SLS – SCALABLE LAB SYSTEM™

## EXCHANGEABLE PLATFORM FOR BENCHTOP POWDER PROCESSING

The Fitzpatrick Company and Quadro Engineering Corp. are part of the IDEX Material Processing Technologies group, and have been trusted partners of the world's top pharmaceutical, chemical and food ingredient processing customers for a combined total of more than 120 years.

This unmatched experience is the fundamental reason why our products and people are recognized throughout the world for the highest standards of professionalism and performance.

### Reduce capital investment with the SLS: four interchangeable heads on a single drive platform

The SLS – Scalable Lab System™ is a unique benchtop powder milling and screening platform that utilizes one common drive platform with a series of interchangeable heads. The SLS eliminates the costly requirement for four individual units in separate locations – ideal for R&D labs and start-ups.

**Learn more, page 4.**

### Save development time: changeout the head for a different process

The four different heads offer a wealth of conical milling, hammer milling and security screening options. With the SLS, you can undertake a test, record the results, and quickly move on to another approach. The SLS will speed up your research and reduce material usage, as well as overall product development time.

**Learn more, page 6.**

### SMARTdetect™ technology ensures repeatability and consistency

Our unique SMARTdetect™ functionality affords the SLS the ability to automatically set the correct RPM range for each technology. Customers now have the ideal platform for reliable and repeatable testing / research within their R&D lab or start-up, with full confidence of accurate scale-up to production-size equipment.

**Learn more, page 8.**

### Extensive screen and impeller options to complement application requirements

Fitzpatrick and Quadro manufacture the industry's most extensive and flexible range of conical and hammer milling screens and impellers / rotors. We help you find the right solution for your application requirements.

**Learn more, page 10.**

### Ready for production? Easily scale-up to the SDx Series™

The SLS offers the perfect path from R&D tests to full-scale production. With all parameters transferring, SLS users can now experiment in small-scale product development knowing that exactly the same results can be duplicated with the production-scale SDx Series™.

**Learn more, page 14.**

### Distinct drive housings offer cleanability options

Available with a medical-grade thermoplastic cover or stainless steel enclosure for more rigorous cleanability requirements. Clean in-situ or remove the head to a cleaning area to further protect operators and maintain a clean lab environment.



**OUR PRODUCTS AND PEOPLE ARE  
RECOGNIZED THROUGHOUT THE WORLD  
FOR THE HIGHEST STANDARDS OF  
PROFESSIONALISM AND PERFORMANCE**

# REDUCE CAPITAL INVESTMENT

## FOUR INTERCHANGEABLE HEADS

### A SINGLE DRIVE PLATFORM

Introducing the world's most advanced benchtop, multi-purpose powder milling and screening platform, utilizing four interchangeable heads on the same common drive. Fast changeovers between heads (rather than switching between different units) means you can experiment and reach your research goals quickly, and with a reduced investment.

The unique design and technology within the SLS – Scalable Lab System™ allows the user to:

- Substitute the requirement for several different powder processing units with a single, flexible platform
- Quickly and easily alternate between five powder processes in seconds
- Improve on-target particle size distributions (PSDs) by up to 50%
- Process samples as small as 5 grams with minimal loss – 95% product recovery for most products
- Easily scale-up from R&D tests to full production

Results are replicated for production-scale processing with the SDx Series™

Fitzpatrick and Quadro's SLS provides users with the reassurance that once they are ready to move to full production, results can simply be transferred from small sample R&D tests to full-scale production with the SDx Series™. With fully transferable parameters, users can expect to duplicate results when transferring to a production-scale environment with the SDx Series™.

Learn more, page 14.

- 1 Powder Processing / Milling Head
- 2 Common Drive Connection
- 3 SMARTdetect™ Interface
- 4 SLS Drive Control System
- 5 User Interface

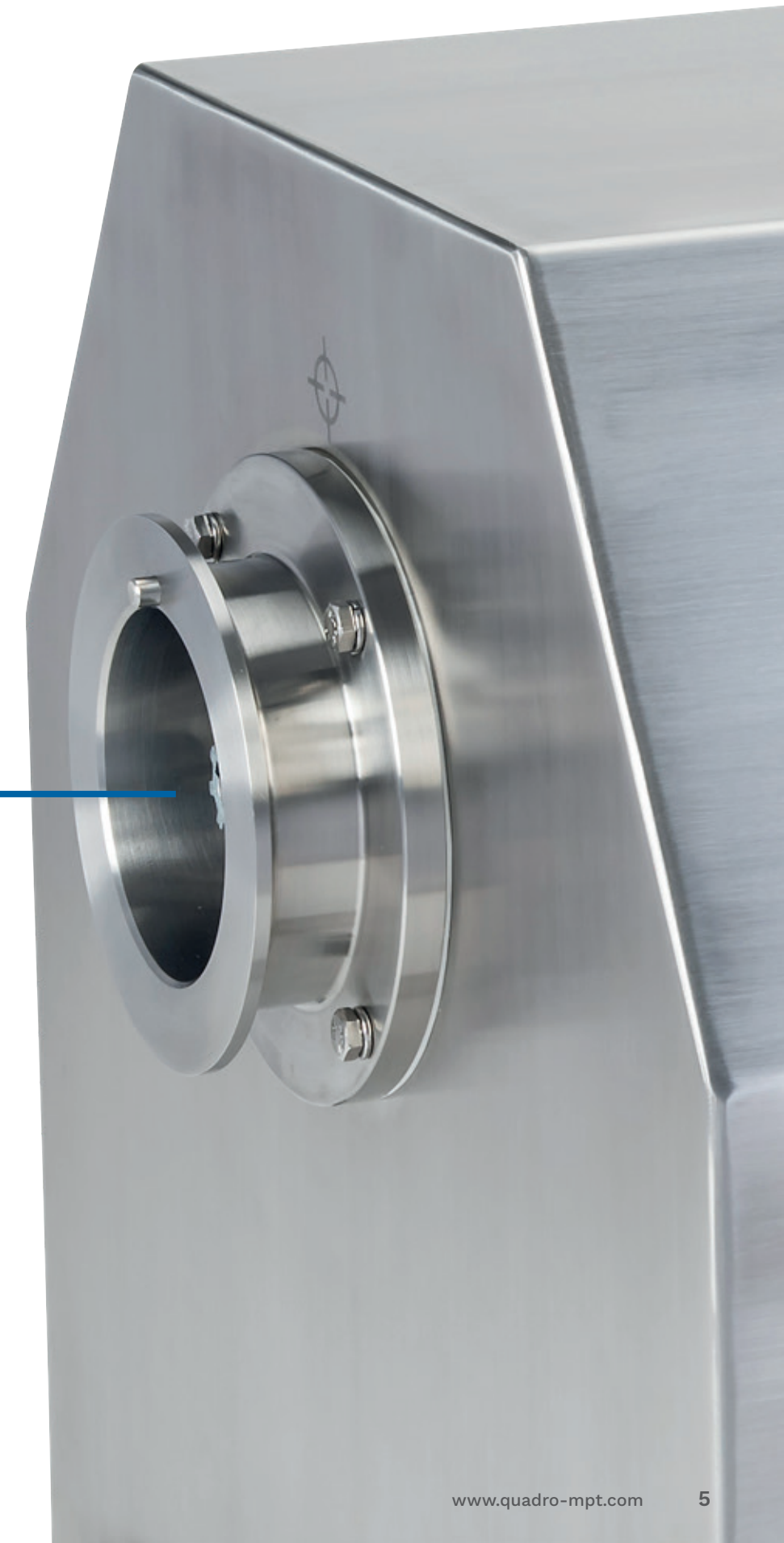
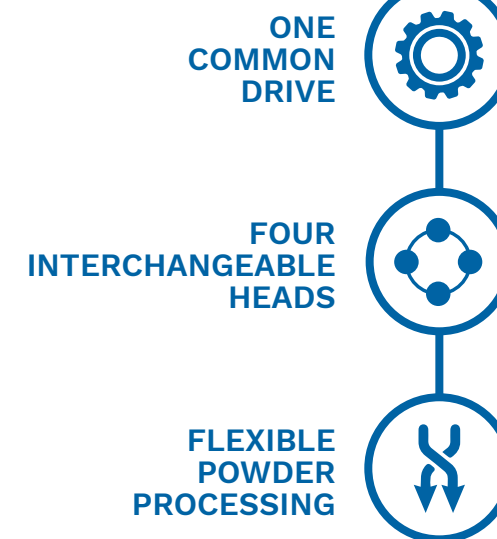

# SAVE DEVELOPMENT TIME

## CHANGEOUT THE PRODUCTION HEAD FOR A DIFFERENT PROCESS

The **SLS – Scalable Lab System™** facilitates the attachment of four custom heads for five powder processing solutions that include conical milling, hammer milling and security screening. Simply choose the type of head that best fulfills your testing requirements.

When ready to transfer results from small-sample R&D testing to full-scale production, users can quickly and efficiently scale-up to the production size SDx Series™. **Learn more, pages 14 and 15.**

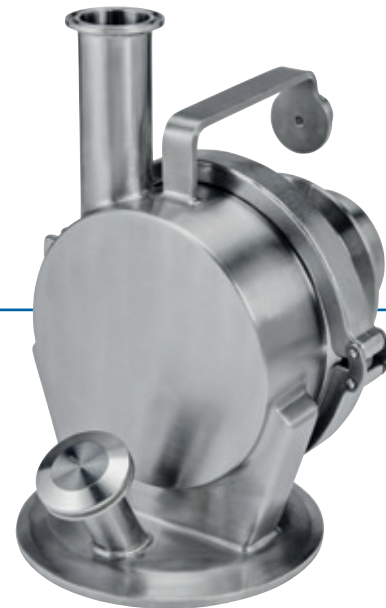

### COMIL® U5

#### Conical Milling

- Available with patented select high-efficiency screens.
- Consistent / repeatable results with tight granulometry.
- Improved product quality with low levels of heat, dust and fines.
- Wide range of scalable screens and impellers from which to choose.
- Fully scalable to the Quadro® Comil® U20x and Classic U20.

### FITZMILL™ L1A

#### Hammer Milling

- High impact hammer mill for achieving finer particle sizes.
- Handles samples as small as 5 grams with minimal loss of yield or screen residue.
- Integrated feed system for optimized containment and predictability.
- Fully scalable to the D6Ax and Classic D6A Hammer Mills.

### COMIL® H5

#### High Energy Conical Milling

- High energy conical milling achieves smaller particle size distributions (PSDs).
- Primarily for APIs, finer oral solid dosage, fine chemical and cosmetic applications.
- Narrow PSDs with 30–70% more on-target.
- Integrated feed system for optimized containment and predictability.
- Fully scalable to the Quadro® Comil® Classic H20 production-scale head.

### FLEXSIFT S5

#### Security Screening

- In-line security screening.
- High capacity for efficient testing protocols.
- Utilizes standard equipment for fast clean-down.
- Fully scalable to the Quadro® FlexSift S20x and Classic S20 production-scale heads.

# UNIQUE SMARTdetect™ TECHNOLOGY SPEEDS TESTING AND RESEARCH

**Our unique SMARTdetect™ functionality gives the SLS – Scalable Lab System™ the ability to operate as four different units from one single base unit. Quick and easy head changeovers allow it to be used for processes including conical milling, hammer milling and security screening.**

SMARTdetect™ automatically recognizes which processing head is attached, and adjusts the platform's RPM range accordingly for the most efficient operability, thereby ensuring reliable and consistent results. With SMARTdetect™ technology and the simple clamp connectivity working together, users can change heads – and production / processing methods – within seconds. For more information on the heads available, **see pages 6 and 7.**

Operator safety is ensured with its interlock proximity switch that prevents operation if the head is incorrectly positioned.



## SMARTdetect™

Our SMARTdetect™ technology gives you failsafe reassurance that the correct processing method is selected automatically. With SMARTdetect™, milling and screening operations can't go wrong.

- **Unique hardware / software technology**
- **Automatically detects which processing head is selected**
- **Sets RPM for repeatable and reliable material processing requirements**

FITZPATRICK AND QUADRO'S COMBINED EXPERTISE HAS ENABLED INNOVATIVE FEATURES TO BE BUILT INTO THIS REVOLUTIONARY PROCESSING PLATFORM

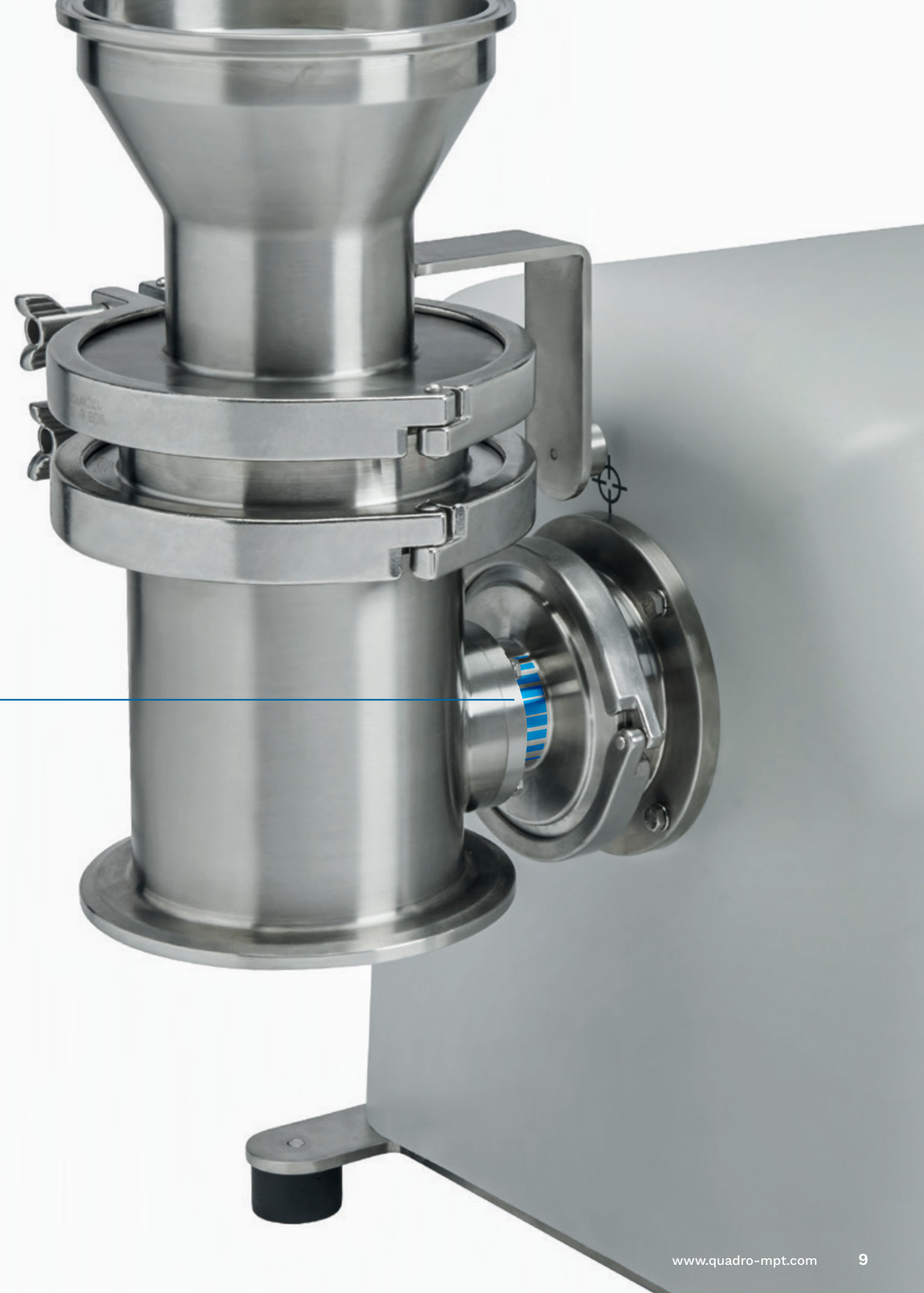

# SCREEN & IMPELLER / ROTOR

## OPTIONS FOR ALL POWDER MILLING AND PROCESSING APPLICATIONS

**Unlimited process requirements and applications can be accommodated using a wide range of available screens and impellers. Customers now have the ideal platform for much faster testing and research within their R&D lab or start-up.**

Fitzpatrick and Quadro manufacture the industry's most extensive, and flexible line of conical and hammer milling equipment available.

Our extensive knowledge of setting the optimum parameters for both milling and screening means we can handle just about any application requirement.

Customers quickly find that it is possible to directly match applications with a unique combination of screen and impeller / rotor to solve their powder processing requirements.

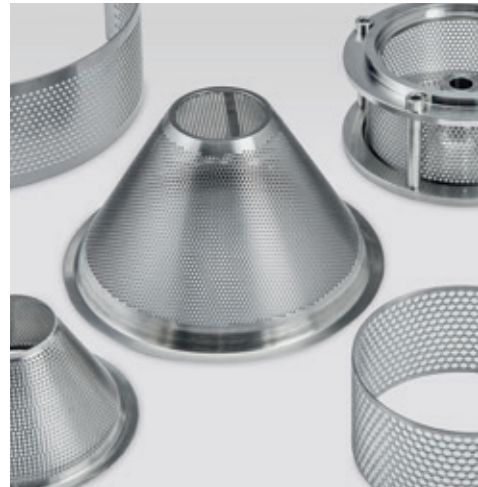

### Range of screens

An extensive selection of screen types and sizes accommodates most particle size requirements. Screens are available with openings as small as 0.150mm (0.006"), and as large as 38mm (1.5"). Screen choices are extended further with options for round or square perforations, wire mesh or for grater or Conidur holes.



### Types of Comil® impellers

Dozens of different profiled impellers can be used to suit the specific application requirements. Basic options include round arm, square arm, or beveled arm impellers. More aggressive and process-specific profiles are also available.



### Configurable FitzMill™ rotor options

The wide range of rotor configurations enables us to achieve the desired particle size distribution (PSD) for your specific process. These uniquely configurable options can solve most powder processing requirements and achieve the tightest PSDs of any hammer mill manufacturer.



DELIVERING THE INDUSTRY'S MOST EXTENSIVE LINE OF API MILLING, ORAL SOLID DOSAGE AND POWDER PROCESSING EQUIPMENT

# TECHNICAL OVERVIEW

## FOR THE SLS – SCALABLE LAB SYSTEM™

The SLS – Scalable Lab System™ has been designed with the user in mind. Simple to maintain, with fewer parts to remove during cleaning cycles, it maximizes uptime and reduces your total cost of ownership (TCO).

## BENCHTOP DRIVE PLATFORM

<b>General Capacities</b>
<b>Speed Range</b>
<b>Power</b>
<b>Noise</b>
<b>Height to Discharge (H)</b>
<b>Height to Inlet (H2)</b>

### U5

kg/hr	up to 50*
m/s	up to 28
kW	0.55
dB	77
mm	220
mm	513

### L1A

kg/hr	up to 50*
m/s	up to 85
kW	0.55
dB	95
mm	162
mm	696

### H5

kg/hr	up to 50*
m/s	up to 72
kW	0.55
dB	88
mm	220
mm	763

### S5

kg/hr	up to 500*
RPM	2500 - 3500
kW	0.55
dB	76
mm	220
mm	551

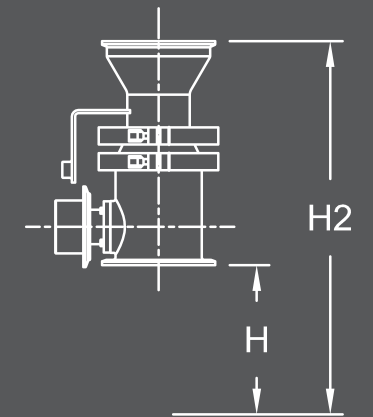
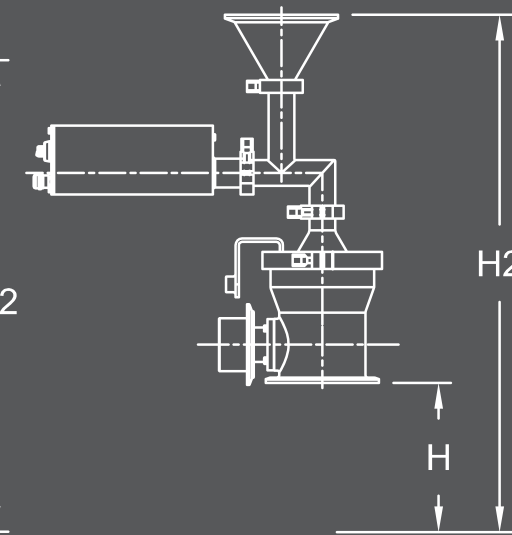
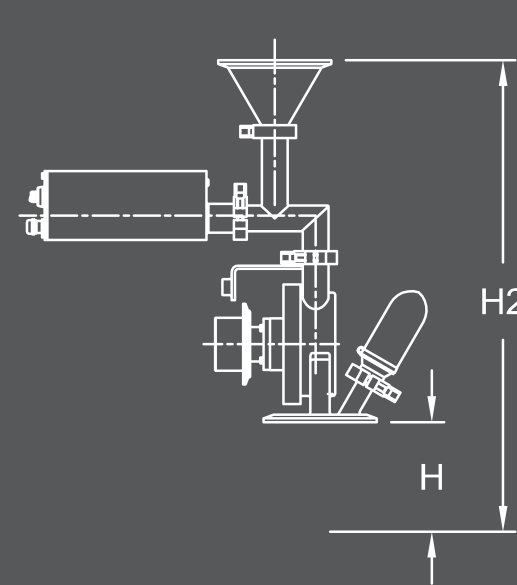
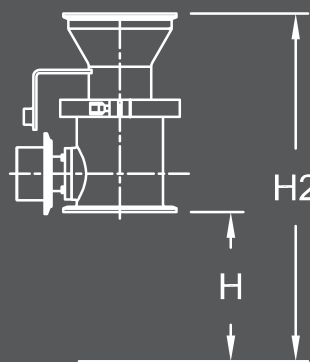
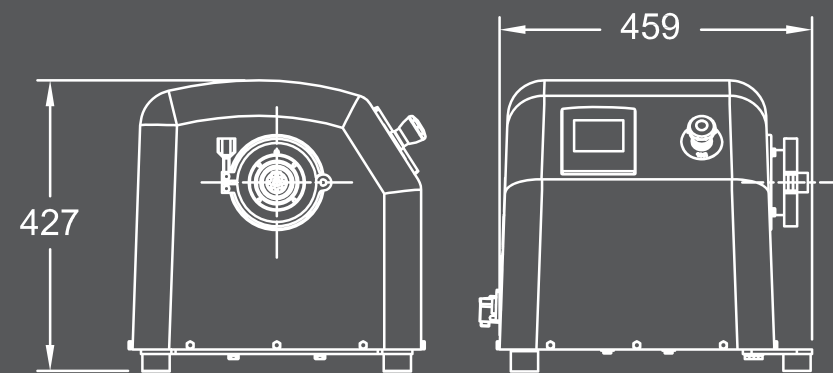

\* Capacity is dependent upon product characteristics, final PSD targets and equipment set-up. For some products, capacities may be significantly higher, or slightly lower, than those indicated above.

#### Simple controls for the lab environment

Integrated HMI controller with logical menu structure and simple controls is standard. Integrated feeder controls are also standard — add a VFS feeder at time of purchase or at a later date, as needed.

#### Unmatched screen and impeller combinations

Over 200 screen types and dozens of different impellers provide an ideal match for all applications. Comes with accessories including hand-feed hoppers and thermoplastic containers.

#### Maximized product recovery

Process samples as small as 5 grams with minimal loss or product retention. 95% product recovery for most products.

#### Accreditations



# READY FOR PRODUCTION? EASILY SCALE UP TO THE SDx SERIES™

Customers that are developing new product lines need to guarantee the easiest path from product research and development through to actual production. Fitzpatrick and Quadro now make the product development path as simple as possible with the ability to scale from testing and R&D size samples to full-scale production without the need for changes in parameters.

The material processing technologies and primary size reduction capabilities all incorporated into the SLS – Scalable Lab System™, are exactly the same as those in the larger, production-scale SDx Series™. Users developing new product lines in a benchtop environment using the SLS can now easily grow into full production with the SDx Series™ powder processing exchangeable platform.

The SDx Series™ offers robust flexibility, with fast head changeovers and SMARTdetect™ functionality. Unparalleled screen and impeller options, as well as the performance and reliability you expect from one of the world's most trusted partners make the SDx Series™ the best choice.



## SMARTdetect™

Our SMARTdetect™ technology provides users with failsafe reassurance that the correct processing method is automatically selected. With SmartDetect™, milling and screening operations cannot go wrong.

- **Unique hardware / software technology**
- **Automatically detects which processing head is selected**
- **Sets RPM for repeatable and reliable material processing requirements**

## Main benefits of Fitzpatrick / Quadro's SDx Series™:

### Unparalleled scalability:

PSD and capacity scalable with simple operating parameters transferrable from R&D testing to full-scale production.

### Reduced space / power requirements:

With the interchangeable heads, the SDx Series™ replaces the need for several, dedicated machines in different locations, each with their own power source.

### Widest range of sample sizes:

Process samples of up to more than 10,000 kg/hr depending on your application requirements, with minimal product loss.

### Fast application conversion:

Easily switch between different powder processing solutions in seconds using SMARTdetect™ technology and standard simple clamp fittings.

### Reduced need for cleaning:

With one common drive, heads can easily be removed and cleaned whilst leaving the drive unit in place for fast changeovers and minimal downtime.



- 1 **Quadro® Comil® U20x**  
Conical Milling
- 2 **FitzMill™ D6Ax**  
Hammer Milling
- 3 **Quadro® FlexSift S20x**  
Security Screening

# INNOVATIVE PRODUCTS BACKED BY WORLD-LEADING EXPERTISE AND SUPPORT

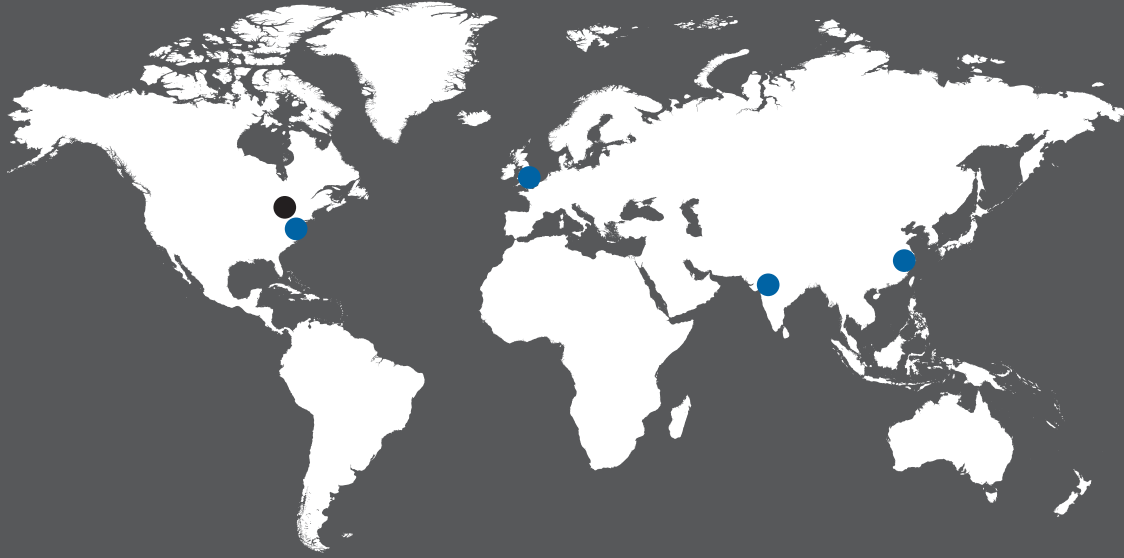

The Fitzpatrick Company and Quadro Engineering Corp. have earned the respect of customers for a combined period of over 120 years.

With over 40,000 equipment installations worldwide, discover what underscores our reputation for supplying high quality powder processing equipment solutions. Trust us to fulfill your specific application requirements.

Discover and experience the Fitzpatrick / Quadro difference!

● Headquarters

● IDEX MPT Centers of Excellence

Representation in over 80 countries worldwide

## **IDEX** Material Processing Technologies



Dry Granulation  
Hammer Milling



Conical Milling  
High-Shear Mixing



Lean Powder Handling  
Batching, Mixing & Packing



High-Pressure  
Fluid Processing

**The Fitzpatrick Company**  
Tel: +1.519.884.9660  
Email: [fitzinfo@idexcorp.com](mailto:fitzinfo@idexcorp.com)  
[www.fitzpatrick-mpt.com](http://www.fitzpatrick-mpt.com)

**Quadro Engineering Corp.**  
Tel: +1.519.884.9660  
Email: [quadrosales@idexcorp.com](mailto:quadrosales@idexcorp.com)  
[www.quadro-mpt.com](http://www.quadro-mpt.com)

613 Colby Drive  
Waterloo, ON, Canada