

LEAF

vertical form, fill and seal machine for paper



EN

GKS Packaging

Inventive simplicity

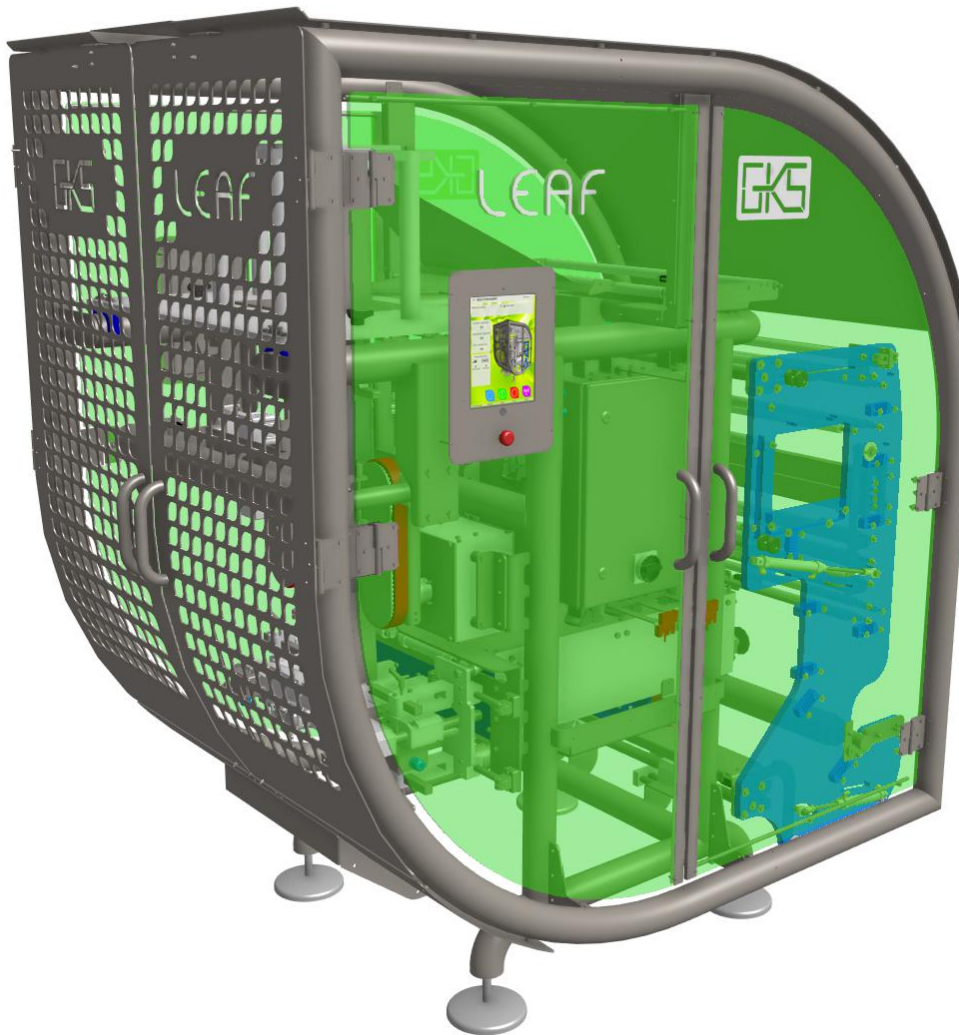

- 100% developed for paper
- High-pressure sealing
- In-line net applicator
- Special former set for paper
- Modular construction
- Allen Bradley PLC and electrical components
- Ipad interfaces on both sides
- Machine status by smart LED lighting
- Low CO₂ footprint



www.gkspackaging.com

LEAF

vertical form, fill and seal machine for paper

Vertical form, fill and seal machine to produce, fill and close bags from flat paper from the roll. The machine is suitable for packing many types of food and non food products.

LEAF is specifically developed to produce paper bags out of 100% recyclable and compostable paper mono material. LEAF has a revolutionary design and is constructed out of stainless steel and other recyclable materials. LEAF is partly built out of recycled OCEAN PLASTIC, thus helping to reduce plastic waste. Together with the open construction for optimized accessibility, it makes the machine very easy to clean and maintain.

LEAF excels in optimized sealing pressure, paper handling and tracking. It has a special former set and is equipped with an in-line mesh applicator to produce bags with a netting behind the window.

With its large range in pack sizes (190 mm up to 400 mm bag width) and a capacity up to 35 bags per minute, LEAF is the perfect machine for all paper applications. In the standard configuration it produces both pillow and stand up bags.

The modular construction guarantees that each module can be exchanged within minutes. This creates a reduction in downtime and costs during maintenance work. Options and components can be retrofitted easily and quickly.

Machine is standard equipped with:

- Stainless steel machine construction; open design
- Machine partly built out of recycled OCEAN PLASTIC
- Machine safety according to CE regulations
- Allen Bradley PLC controls and components
- iPad interfaces on both sides with intuitive controls
- Machine status by smart LED lighting
- Stainless steel cover plate over the entire paper lane
- Photocell for bag length detection with pre-printed paper
- End of film detection
- Splice table
- Servo driven film transport
- Ergonomic film support with with motor driven film roll and tensioning system
- Automatic lateral film adjustment
- In-line net applicator
- Special forming set for paper

Options:

- Asymmetrical forming set
- Special feeding funnel (carrots, potatoes, etc.)
- Bag support system
- Tilting device
- Cooling at length seal
- Cooling at horizontal sealing jaws
- Thermal transfer printer
- Label applicator
- Special sealing profiles
- Punch hole system
- Integration with MES system based on OPC server
- Funnel buffer system

LEAF

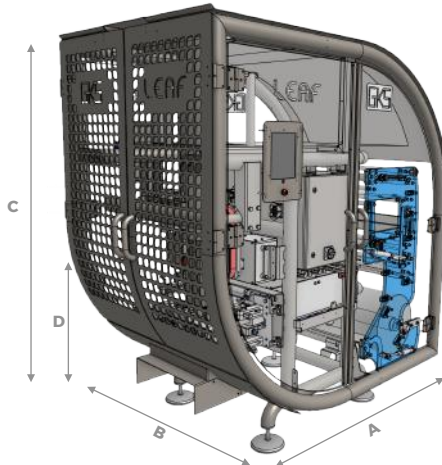

LEAF A B C D
1950 1250 2000 675 mm

Technical specifications:

	LEAF	
Bag width (pillow)	190 - 400	mm
Max. bag length	unlimited	mm
Max. bag length per sealing step	480	mm
Max. production speed	25	bags/min
Paper thickness	25 - 150	μ
Core diameter	76 (3")-152 (6")	mm
Max. film width	840	mm
Max. outer diameter paper roll	600	mm
Voltage	400V 16A, 50/60	Hz
Power consumption	2500	Watt
Air consumption (min. 8 bar)	500	ltr/min

All dimensions and specifications are indications based on standard set up. Final details depend on customer specifications

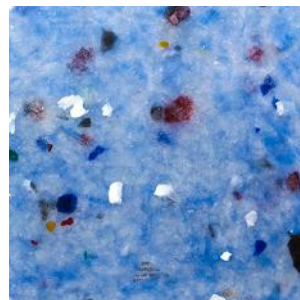

GKS Packaging

Steenoven 18
5626 DK Eindhoven (NL)
+31 (0)40 2095 040
sales@gkspackaging.com